

Hotel-grade electrical energy storage cabinet with constant temperature and humidity



Hotel-grade electrical energy storage cabinet with constant temper



Constant temperature and humidity storage cabinet GNC80HS

Constant temperature and humidity cabinets are widely used in products that need to be stored under specific temperature and humidity conditions, such as: semiconductors, chips, optical instruments, ...

[Get Price](#)

Constant Temperature and Humidity Cabinets , Electrical Tool Storage

JINPOWER offers constant climate cabinets for storing electrical tools under controlled temperature and humidity. Ideal for insulating equipment, with digital monitoring and customizable layout.



[Get Price](#)



- IP65/IP55 OUTDOOR CABINET
- ALUMINUM
- OUTDOOR ENERGY STORAGE CABINET
- OUTDOOR MODULE CABINET

Humidity Controlled Cabinet: Temperature Controlled Cabinet

The temperature and humidity controlled cabinet range supplied by Blundell is designed to ensure that a constant temperature is maintained, and the relative humidity is kept between 1% - 5%. Dry storage ...

[Get Price](#)

Detail Humidity Cabinets: Advanced Moisture Control for ...

A humidity cabinet is a specialized storage unit that maintains low humidity levels. These cabinets are crucial for protecting moisture-sensitive items like electronics and pharmaceuticals from ...

[Get Price](#)

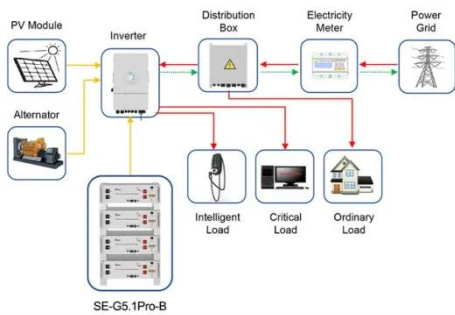

Application scenarios of energy storage battery products

HUMIDITY & STABILITY CHAMBERS

LAB CHAMBERS PRECISION STORAGE
Designed to meet the demanding requirements for precise humidity and stability, Advanced engineered design incorporates the latest in cabinet, refrigeration, ...

[Get Price](#)

Cabinet Type Constant Temperature and Humidity Machine

The SIMN XHH Series represents the pinnacle of precision environmental control technology, combining advanced temperature regulation with intelligent humidity management in a compact cabinet design. ...

[Get Price](#)



Energy saving constant humidity storage cabinet

Energy saving constant humidity storage cabinet, using fiber humidity regulator and constant humidity control module

linkage for humidity control, high airtightness, working in the constant humidity mode ...



[Get Price](#)

INDUSTRIAL AND COMMERCIAL ENERGY STORAGE CABINETS

Product Overview Industrial and commercial energy storage cabinets are a modular and integrated energy storage system specifically designed for industrial and commercial scenarios such ...



[Get Price](#)



Liquid-cooled Energy Storage Cabinet

High Safety and Reliability o High-stability lithium iron phosphate cells. o Three-level fire protection linkage of Pack+system+water (optional). o Supports individual management for each cluster, ...

[Get Price](#)

Temperature and Humidity Control Cabinets for Precision Storage

Discover precision temperature and humidity control cabinets with CE

certification. Ideal for semiconductors, instruments, and drying applications.

[Get Price](#)



Contact Us

For catalog requests, pricing, or partnerships, please visit:
<https://www.k3gizycko.pl>

